



Vision Micro Hardness Tester
MicVision VH-1
Operation Manual

Sinowon Innovation Metrology Manufacture Limited

www.sinowon.com

Preface

1. Carefully read the Operation Manual before you use the hardness tester and get to know thoroughly the operation procedure and the usage precautions so as to avoid the damages to the hardness tester and the safety accidents caused by the improper operation.
2. All the bands and the anti-shock tapes should be carefully removed before the hardness tester is installed and calibrated.
3. The single-phase 3-pin socket should be used for the power source of the hardness tester and the ground connecting cable should meet the safety requirements.
4. It is strictly prohibited to tamper with the installed position of all the electric component parts, switches, and sockets of the hardness tester without permission, otherwise it will cause accident.
5. Our company tries to improve the quality of the hardness testers and renew their structure. In case the contents in the Operation MANUAL are a bit different with the actual structure of the instrument, it is hoped and apologized for the fact that the further notice will not be given.

Contents

1	Hardness Introduction.....	1
2	Technical Specification.....	2
3	Installation and Testing.....	3
3.1	Operational Conditions.....	3
3.2	Unpacking and Installation	3
3.3	Introduction to the Panel Board and Its Functions.....	4
4	Operating Instructions.....	6
5	Operation.....	7
6	Adjustment and Attention.....	13
7	Attached Lists.....	14
8	Usage Method of Knoop (HK) Hardness.....	15
9	Storage/Transportation/ Attention.....	16

1 Hardness Introduction

- The Micro Vickers Hardness Tester is a new type high-tech product combining the optical, mechanic and electronic techniques; with a novel and pleasing appearance, operational functions and reliability, besides, it has a special characteristic that the indenter and the objective switching are automatically rotated to complete, hence it is an ideal instrument for the testing of micro-hardness.
- Made with a precise design in the field of mechanics, CPU control of the testing process in the electric field, and adopted the highly clear optic testing system in the field of optics, its main functions are as follows:
 - ◆ The selection of HV and HK scale;
 - ◆ Automatically switched between the indenter and the objective;
 - ◆ Inputting by means of the touch keys on the operating board, presetting of the dwell time for test force, regulation of the intensity for measuring light source;
 - ◆ After keying in the diagonal line length of indentation through soft keys, the hardness value will be automatically shown on the screen.
- According to the particular requirements of the client, the instrument can be equipped with CCD device. The instrument is suitable for testing the micro and thin pieces, the parts with the permeated and coated surface, it is also fit for testing Vickers and Knoop hardness value for the crisp materials such as the agate, glass, ceramics and it is, therefore, an ideal hardness measuring instrument for the scientific research institutes, the universities and colleges, the industrial production units and the metrological institutes using with for studying and measuring.
- Hardness measurement software iVicky3.0 Main realization based on video image automatic vickers hardness measurement function (Customizable brinell hardness function) .
- Connection control hardness tester equipment, indentation image captured by the industrial camera, automatic measure vickers hardness;The output and the measured data are statements, measuring process is simple and quick, the measuring results are accurate and stable.
- Operating system : Microsoft WindowsXP/Windows7/ Windows8/8.1/ Windows10 (32/64 bit operating system) .

2 Technical Specification

Product Name	Vision Vicker Hardness Tester	
Product Model	VH-1	
Product Code#	823-110V	
Test Force	gf	10、 25、 50、 100、 200、 300、 500、 1000
	N	0.098、 0.246、 0.49、 0.98、 1.96、 2.94、 4.90、 9.80
Optical System	Observe and Measure Objectives : 10X/40X	
Turret	Auto Rotating Turret	
Test Range	1HV-2967HV	
X-Y Testing bench	Size:100 X 100mm ; Route:25X25mm ; Resolution Rate:2um	
Loading Contro	Auto loading dwell and unloading	
Dwell Time	5-60s adjustable	
Illumination	LED / Halogen adjustable	
Measuring System	iVicky 3.0 Auto Measuring Vickers System	
PC System	Operation System	Win10
	Screen size	10.6"
	CPU	Intel I3
	USB	Double USB (could insert USB and soft dog)
	RAM	2GB
	Hard Disc	32GB
	Camera	1.3MP Pixel, 1/2" CMOS Color Camera
Max Height of Specimen	70mm	
Instrument Throat	95m	
Power Supply	AC220V/50Hz; AC110V/60Hz	
Dimension	425x245x490mm	
Packing Dimension	500x490x700mm	
Gross /Net Weight	47Kg/36Kg	
Execution Standard	ISO6507 , ASTM E92 , JIS Z2244 , GB/T4340	

3 Installation and Testing

3.1 Operational Conditions

- 3.1.1 Room temperature within $(23\pm 5)^{\circ}\text{C}$;
- 3.1.2 Installed in a horizontal position on a solid basement;
- 3.1.3 In an environment without any vibration or corroding agent;
- 3.1.4 Relative room humidity inferior to 65%.

3.2 Unpacking and Installation

- 3.2.1 Cut the packing belt; take out the anti-shock cushion and take out the instrument and the accessories kit from the packing box;
- 3.2.2 Place the instrument on the prepared solid working table; (for the construction of the working table, $< 600\times 350$, and the proposal height of working table is about 600 mm.)
- 3.2.3 Take out the 4 horizontal regulating screws out of the accessories kit and screw them in the holes on the base panel of the instrument. Unpack the gauze band wrapped on the lifting screw and the hand wheel (see Fig.1).

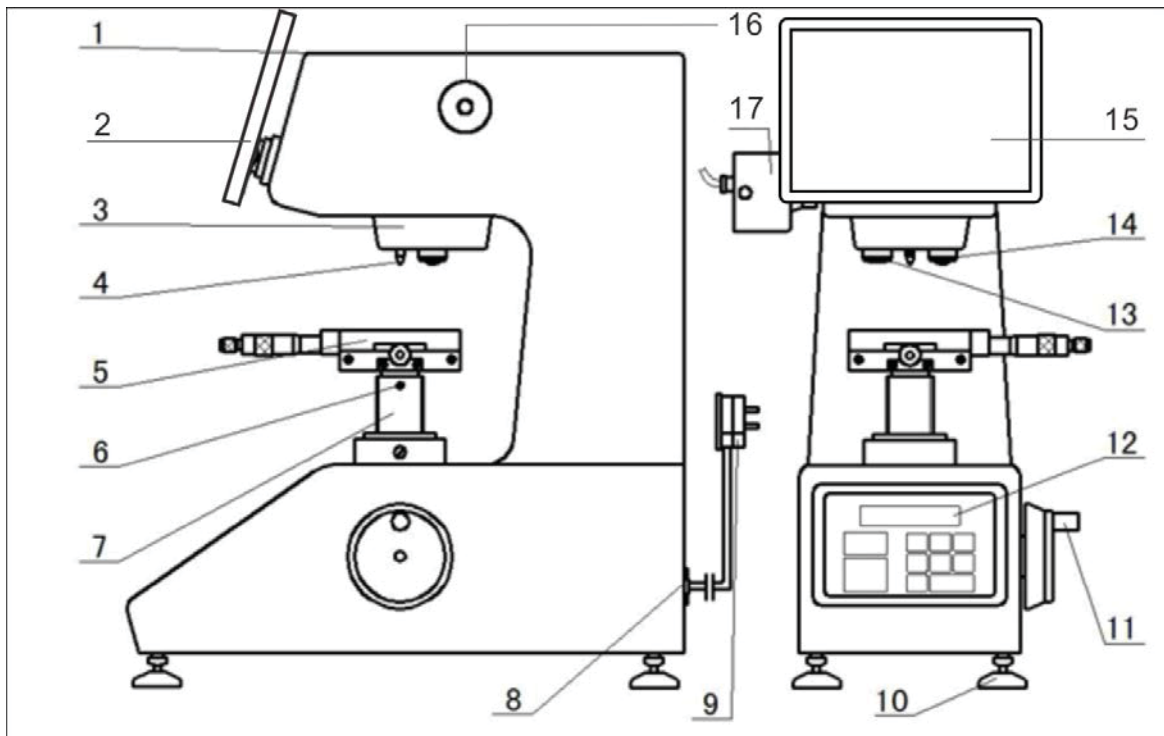

Fig 1

- 3.2.4 Rotate the turntable to make the indenter face the front direction and then tear lightly the anti-shock sticking paper on the indenter with both the hands .Clean the indenter lightly with the lens-cleaning paper dipped with some ether;(just move the lens-cleaning paper on the indenter several times by holding the paper on both ends with hands);
- 3.2.5 Open the upper cover and screw off the two anti-shock screws (see Fig.2);

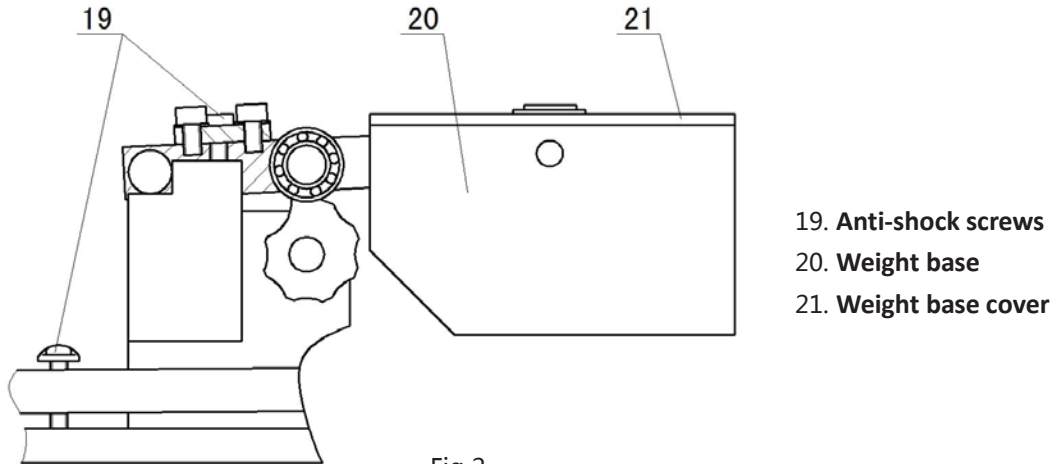

Fig 2

3.2.6 Tear down the belt of the weight base and unload the weight base cover. Take the weight axis and weights out of the accessories kit and clean them thoroughly, (clean the supporting surface of the weight axis with cleaning gauge dipped with some oil so as to protect it against rust;) put the 6 weights on the weight axis in the order from small to big (see Fig.3);

3.2.7 Hold the top of the weight axis, put the axis into the weight cover and rotate the weight axis so that the peg on the lower part of the axis may fall into the V-shaped groove on the lever, and cover the weight base cover;

3.2.8 Rotate the load-change hand wheel so as to make the weight base move smoothly on the position-fixing groove;

3.2.9 Take off the dust-protecting cover of the eyepiece tube and put the eyepiece into the hole, which must be inserted in the end;

3.2.10 Take out the cross testing table and put the axis into the hole of the lifting screw and fix it with screws;

3.2.11 Take the level (the leveling gauge) out of the accessories kit and put it on the cross testing table, and regulate the horizontal screws so as to make the water bubble stay in the center.

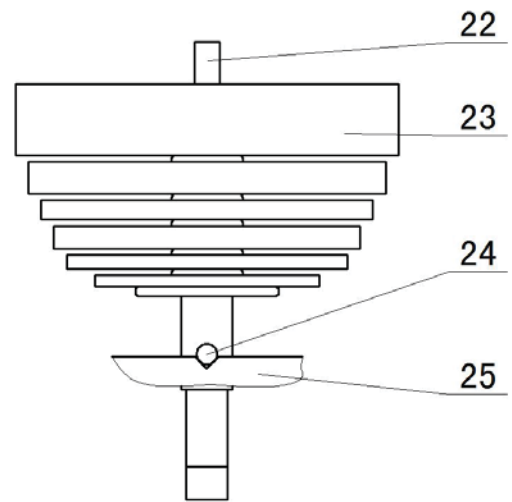
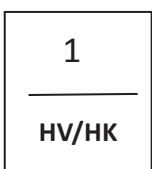

Fig 3

22. Weight axis 23. Weights
24. Weight axis peg 25. V-Shaped groove

3.3 Introduction to the Panel Board and Its Functions (Fig.4).



Upper key: Digit 1
Lower key: The shifting key between Vickers and Knoop hardness test.

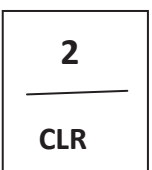

Upper key: Digit 2
Lower key: Zero setting key, press this key to set the zero.

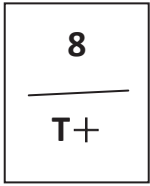

Upper key : Digit 8
 Lower key : Time adding key, every pressing adds 5 seconds

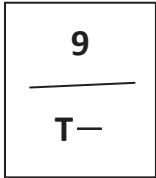

Upper key : Digit 9
 Lower key: Time reducing key, every pressing reduces 5 seconds

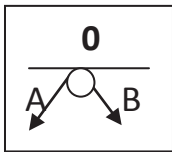

Upper key: Digit 0
 A/B Key: Shifting Key. Shift between objectives and indenter when press this key.

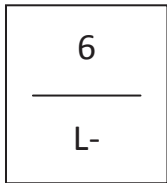

Upper key : Digit 6
 Lower key: reduction key for the luminosity of light source.



Upper key: Digit 7.
 Lower Key (Start key): Press this key to start the motor and apply test force.



Double pressing this key means confirmation. For example, after key in D1 value 202, double press ▽ this key to confirm D1. As same, after key in D2 value 203.5, double press ▲ this key to confirm D2. The hardness value on the screen will show "HV: 721.4" .



Upper key: Digit 4.
 Lower key: After press SPEC key, press this key to let all Upper kevs (diait kevs) become valid and the cursor will blink.

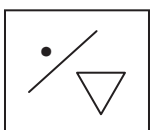

Upper key: Radix point.
 Lower Key: After press SPEC key, press this key to let the Lower keys become valid and the cursor will disappear.

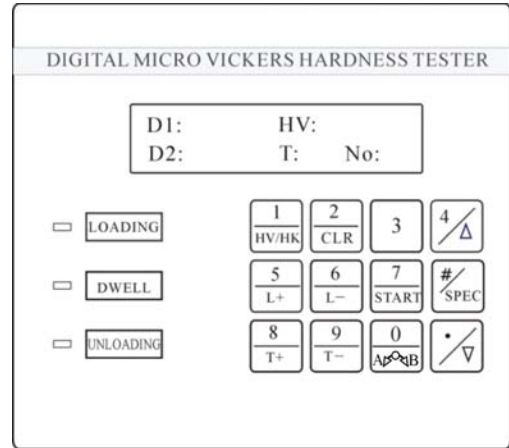

Fig 4

4 Usage of the Instrument

- 4.1 Rotate the load-change hand wheel to make the testing force to meet the requirements of the selection. When rotate the load-change hand wheel, do it slowly so as to avoid the impulsive force caused by any fast movement.
- 4.2 Turn on the power switch. The LCD screen (12) lights up, and the indenter and objective turn automatically to make the 40×objective (14) face in the front direction of the working position. The general amplification is 400×. (The eyepiece, objective and specimen are in the focusing state.)

D1: 0.0	HV:	
D2:	T:10	N:00

- If the luminosity of the light source in the vision field is too dark or light, please regulate it through pressing the key "L+" or "L-" .
 - Press the "START" key on the operating board, the indenter rotates automatically to the working position.
 - Apply the testing force automatically and the (LOADING) LED glitters.
 - After test force applying is completed, the (DWELL) LED lights up, and at this time, the T (Dwell Time) indicated on the LCD screen shows back-count of the time till to 0.
 - After dwell time of test force is up, the (UNLOADING) LED glitters, and the instrument automatically unloads the testing force.
- After the (UNLOADING) LED is off, the 40×objective shall turn to the working position (face in front direction of the instrument) automatically. The buzzer sounds beep.



After the focusing operation is finished, the distance between the tip of indenter and the plane of specimen is about 0.4mm. When the irregular-shaped specimen is to be tested, take care not to damage the indenter owing to the touching of the indenter with the specimen.

5 Operation

5.1 Main Menu : Measure Page;Calibration Page; Setting Page; About Page.

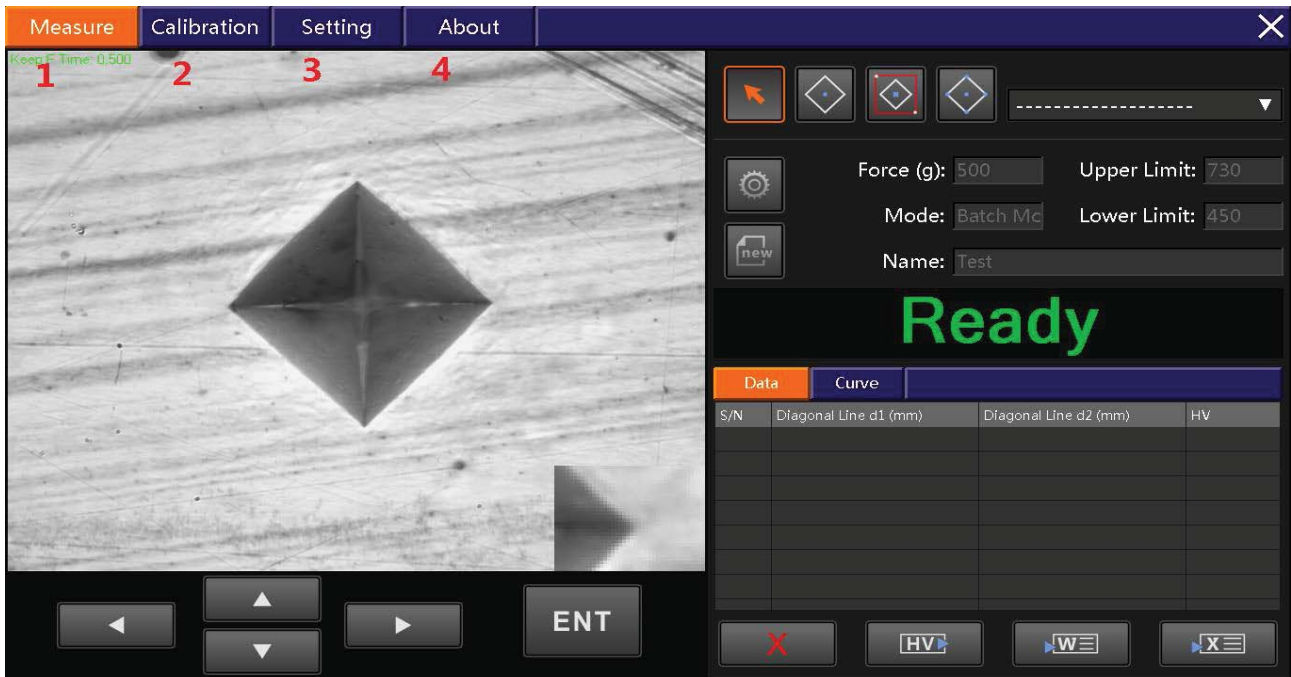

5.1.1 The Ivicky3.0 Measure Menu is realized the testing of Vickers Hardness, setting the measure parameter, display the test data and output the result of testing.

Including Six Region: 1. Video; 2.Measuring Instrument; 3.Calibration; 4.Setting and display the parameter of measure; 5. Display testing result and output; 6.Operating Measure.

5.1.1.1 **Video Display** : Display the real-time image of indentation, It is capable of setting point and testing on the region and confirmation the result of measurement.

5.1.1.2 **Measure Instrument** :

- **Auto measure diamond:** Click "ENT" , the system could automatic find the four point of diamond shape and measurement.
- **Frame select diamond:** During the video region select diamond shape then click "ENT" , the system could auto finding the four point of diamond shape and measurement.
- **Select four point measure diamond:** During the video region, click the four point of diamond shape then please click "ENT" , confirm measure diamond shape.

5.1.1.3 **Calibration Option** : Option different magnification calibration (this magnification have been calibrated).

5.1.1.4 Vickers Measurement Setting: Including setting parameter and building new measure.

1) Setting Parameters : Please click "  " as follow include Indentation Force, Conversion Standard, Dwell Time, Upper Limit, Lower Limit, Mode, Average.

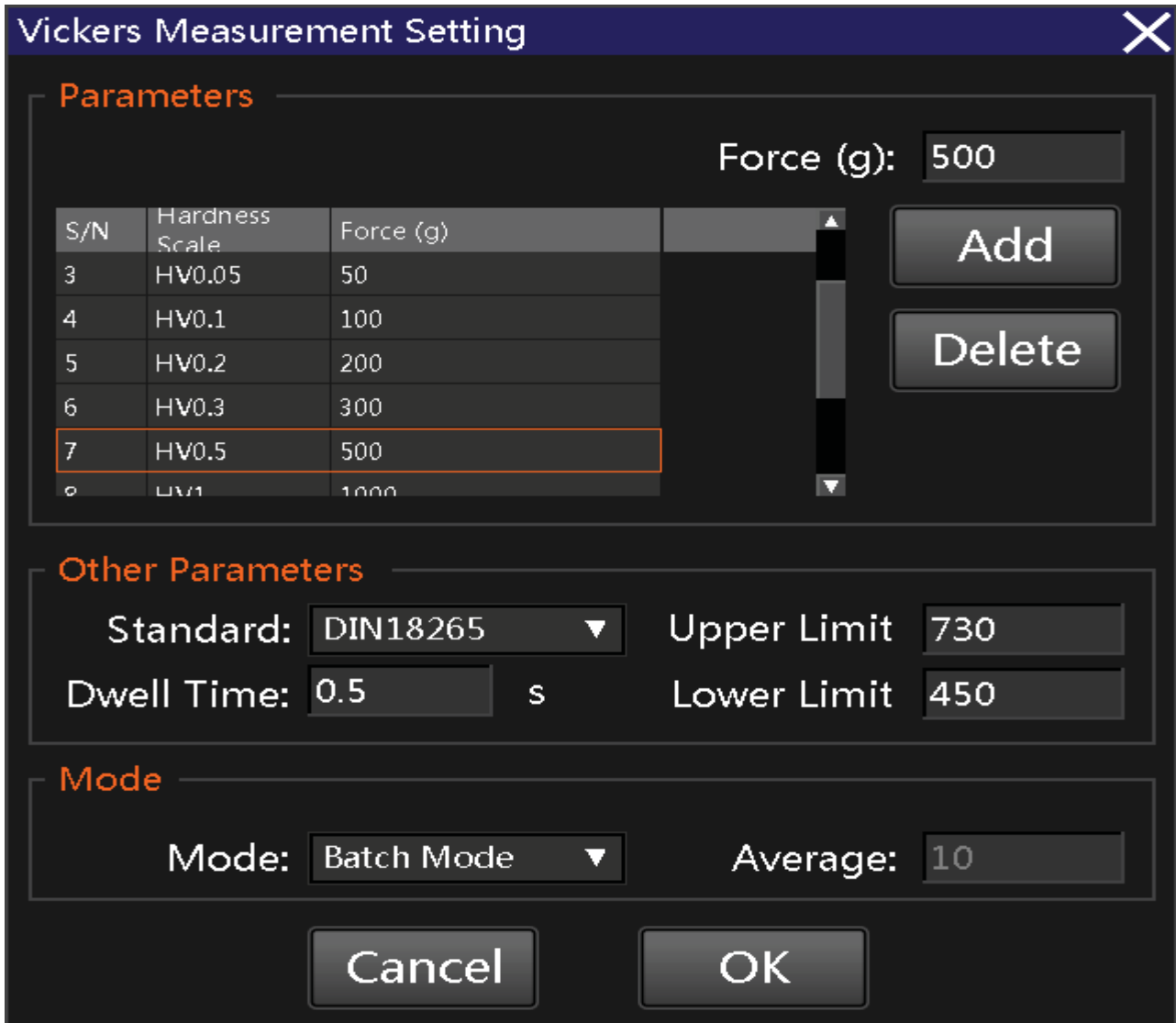

2) New Measurement : Click New Measurement as follow :

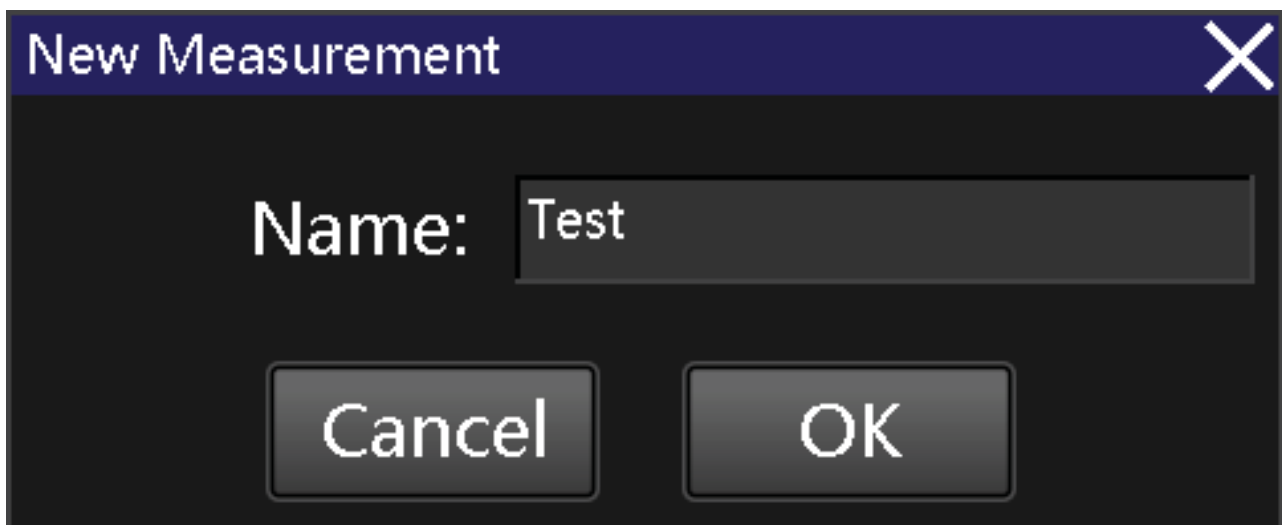

Enter the measurement name, press the "ok" button, and a new measurement will be created. The previous measurement data will be deleted.

5.1.2 Display Measure Result and Output

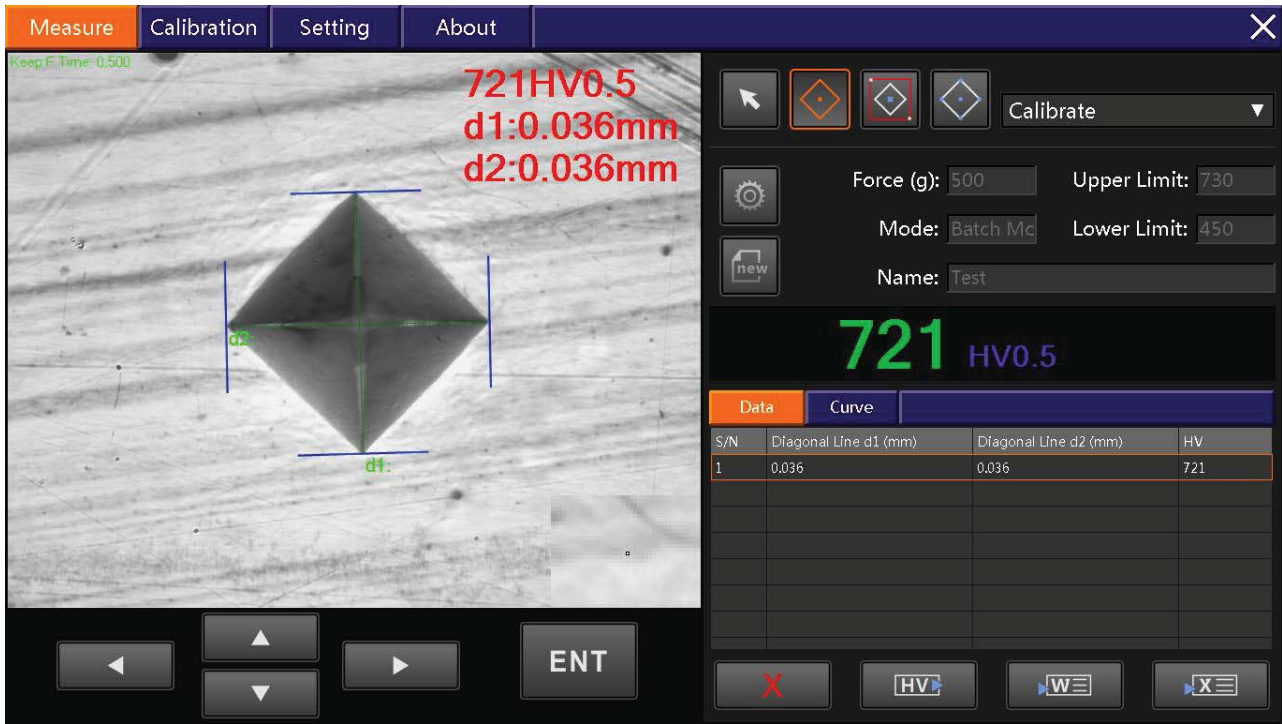

5.1.2.1 Delete : Delete last record 

5.1.2.2 Hardness Conversion : Click Hardness Conversion as follow (contain 17 Hardness Content) 



5.1.2.3 Output Word  and Excel Data 

Vision Micro Hardness Tester Operation Manual

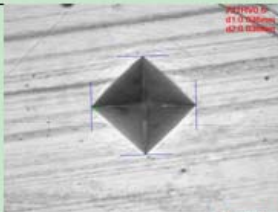
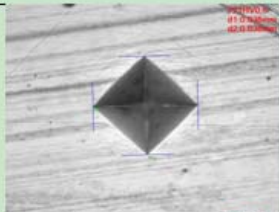
	A	B	C	D	E	F	G	H	I	J	
1	Vickers Hardness Measurement Report										
2	Vickers Hardness Measurement Report										
3	Department:	DepartmentA			Date:	2016-06-23		Operator:	OperatorA		
4	Specimen:	Test			Quantity:	4		Sampling Rate:	100%		
5	Parameters:	Force (gf)	Lower Limit	Upper Limit	Dwell Time	K=0.102F/D2		Standard			
6		500	450	730	0.5s			DIN18265			
7											
8	S/N	Diagonal Line d1 (mm)	Diagonal Line d2 (mm)	HV	--	--	--	--	MPa	NG/Pass	
9	1	0.036	0.036	721						Pass	
10	2	0.036	0.036	721						Pass	
11	3	0.036	0.036	721						Pass	
12	4	0.036	0.036	721						Pass	
13											
14											
15											
16	1					2					
17											
18											
19											
20											
21											
22											
23	3					4					
24											
25											
26											
27											
28											
29											
30											
31	Total	Average	Min	Max	Error Range	Deviation	CP	CPK			
32	4	721	721	721	0	0	0	0			
33											
34											

5.1.2.4 HV Curve is display the measurement result by curve, include CPK and Error range CP etc. as follow.

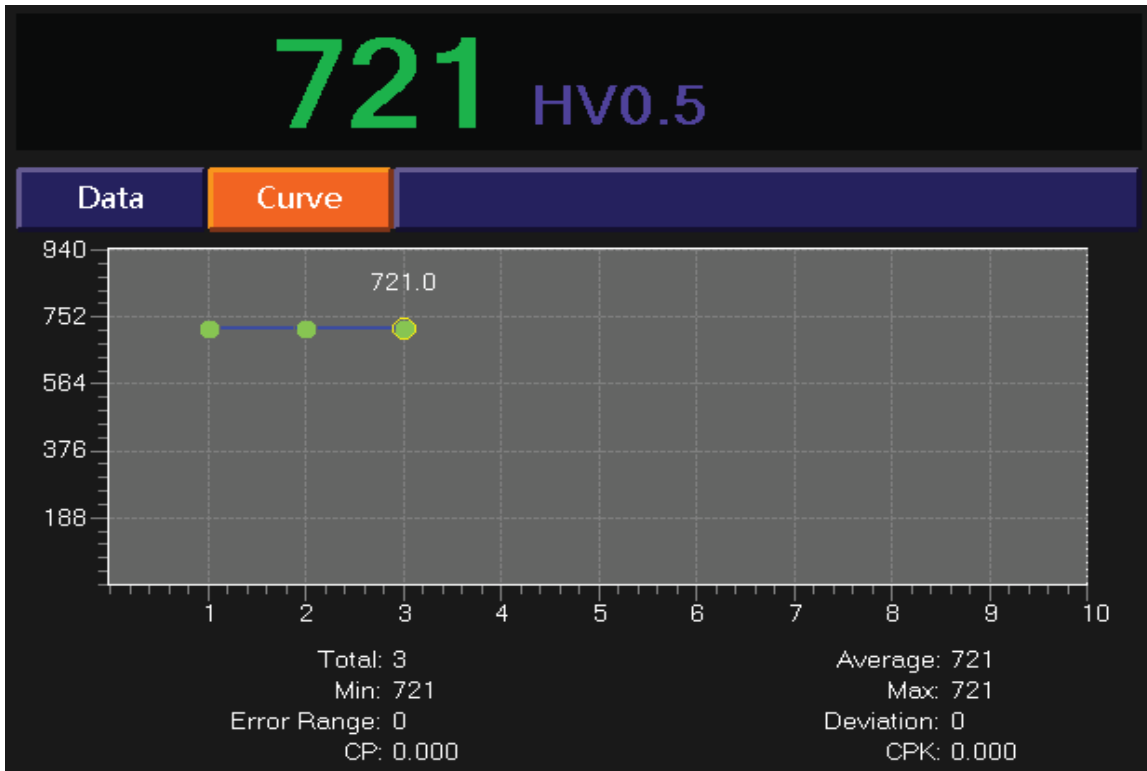

5.1.2.5 Operation Menu :This region main measure, UP and Down, Lift and Right could control the measure points, ENT mean confirmation measurement.

5.1.3 Calibration Page : This menu mean calibrate the different magnification.(It is important to make sure calibration accuracy). 1.Video; 2.Testing instrument;3. Calibration operate 4. Measure operate.

5.1.3.1 Video Display : Display the real-time image of indentation, It is capable of setting point and testing on the region and confirmation the result of measurement.

5.1.3.2 Measure Instrument

- 1) Select measurement roundness: during the video display region please select circular and click the right. Then measure circular diameter.
- 2) Three point drawing circular: click three point and click right .
- 3) Auto measure diamond: Click "ENT" , the system could automatic find the four point of diamond shape and measurement.
- 4) Frame select diamond: During the video region select diamond shape then click "ENT" , the system could auto finding the four point of diamond shape and measurement.
- 5) Select four point measure diamond: During the video region, click the four point of diamond shape then please click "ENT" , confirm measure diamond shape.

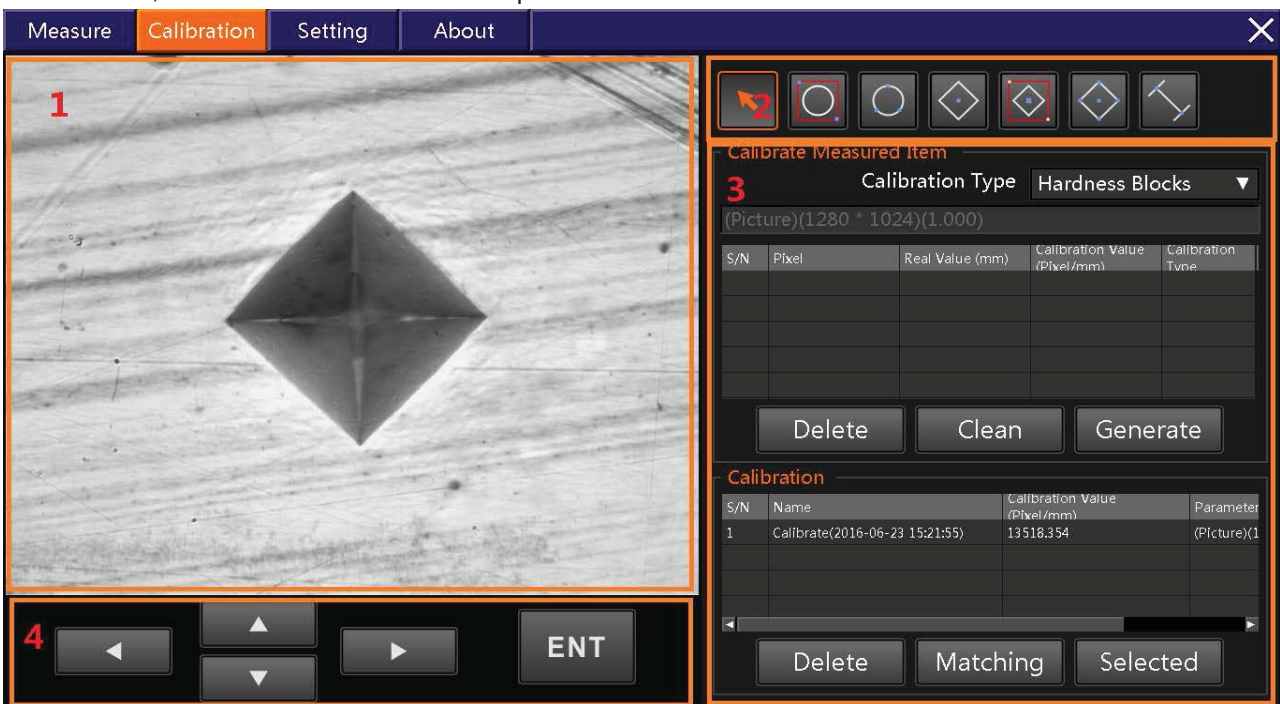

5.1.3.3 Calibration Operate

- 1) Calibration Method: By calibration screen and HB block.
- 2) Calibration Item: One testing data one item.
- 3) How to creative calibration: By testing item and AVG.
- 4) Calibration: a camera and a magnification correspond a calibration record.
- 5) Automatic Calibrate and Manual Motive Calibrate.

5.1.3.4 Operation Menu :This region main measure, UP and Down, Lift and Right could control the measure points, ENT mean confirmation measurement.

5.1.4 Setting Page : System Setting; Camera Setting; Drawing Setting

5.1.4.1 System Setting :

- 1) Operator Name Setting: Using operator name is ok.
- 2) Passport Setting: some important authority need set passport.
- 3) Report Parameters Setting: setting some data you want to output.
- 4) Show Result: Bar graphic and curve graphic.
- 5) Language Chinese and English.

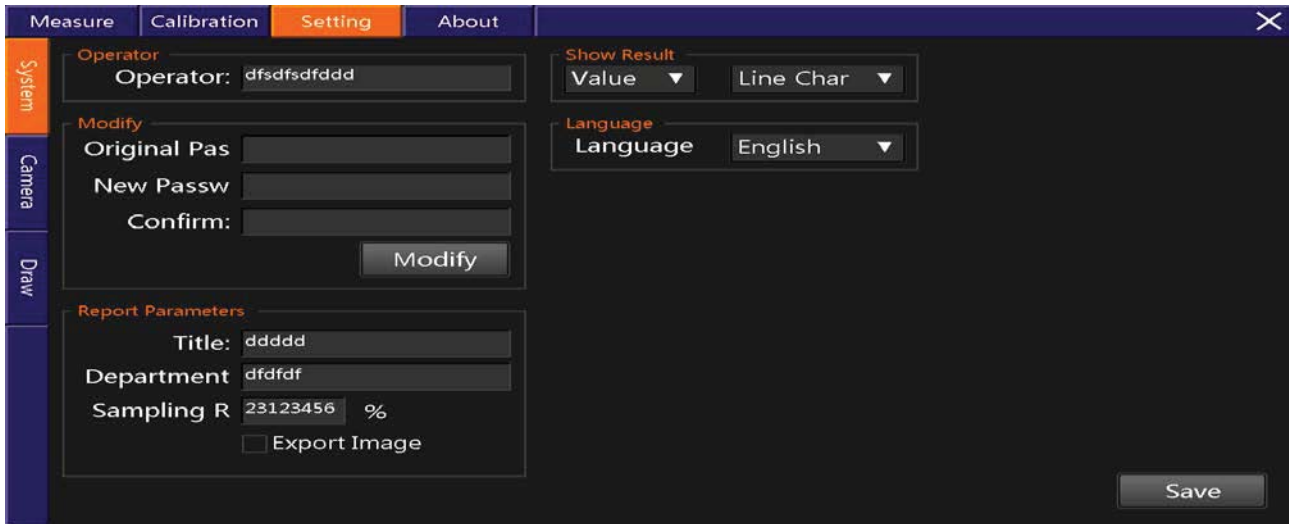

5.1.4.2 Camera Setting : Contain Settings : Camera Type; Virtual Camera; Real-time information; Light Source.

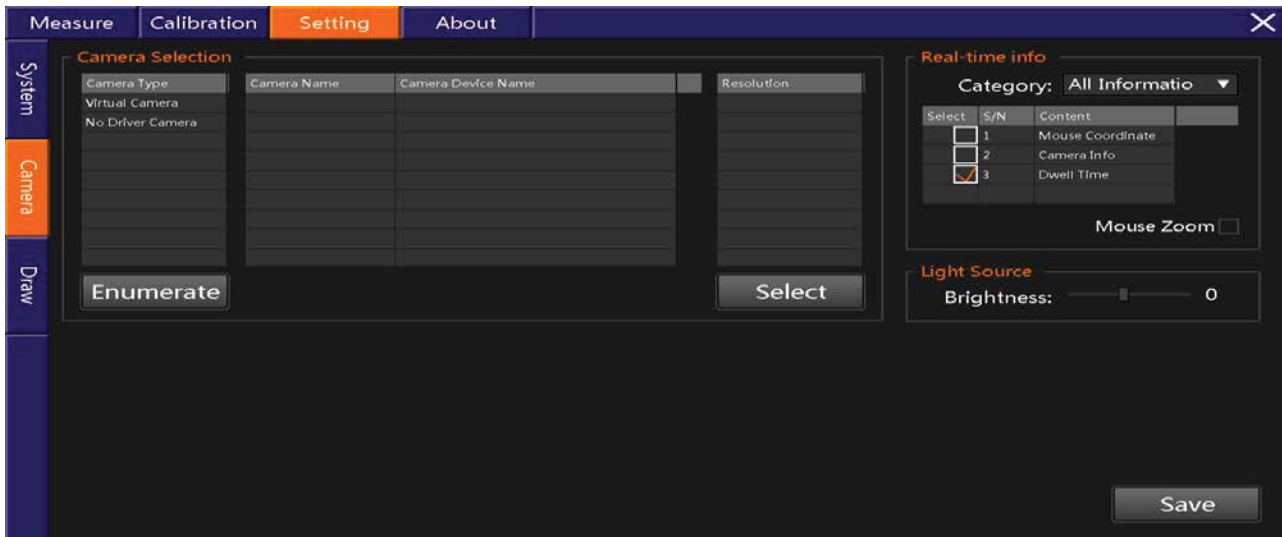

Draw Setting : Include Font Size, Line Width, Line Type as follow:

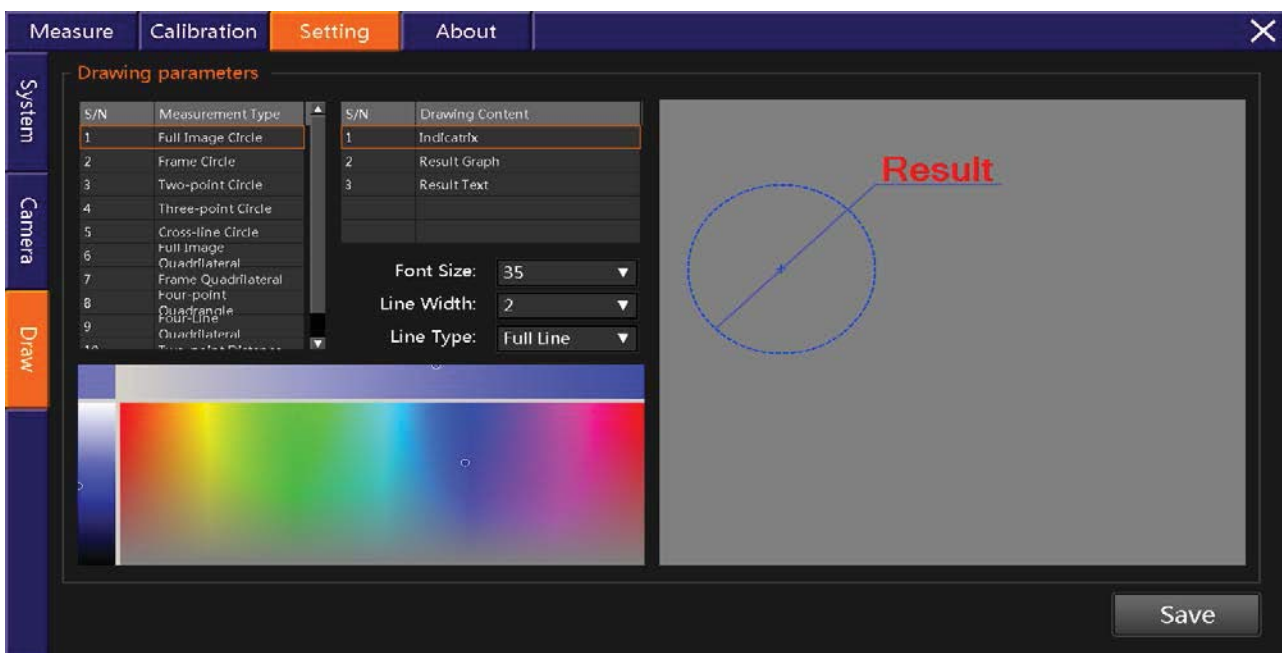

6 Adjustment and Attention

6.1 Diamond Indenter

6.1.1 The diamond indenter and indenter axis are important parts of the instrument, and hence it is necessary to take care not to collide with the indenter during the operation.

6.1.2 In order to assure the precision of the measurement, it is important to keep the indenter clean. If it is covered with grease or dust, it should be cleaned carefully with absorbent cotton dipped with alcohol or industrial ether, especially the tip of the indenter.

6.1.3 The round column of the indenter is marked with a red dot. If the indenter is once unloaded, take care to make the red dot face the frontal direction when it is reloaded, and the focus of the diagonal lines of the indentation should be aligned with the red dot. It is possible to make the alignment of the cross-shaped line in the eyepiece with the diagonal lines of the indentation. If the indentation observed is not aligned with the cross-shaped line, please unscrew the screw on the indenter, turn the indenter a bit and fasten the screw, and then make the alignment again through tests until the alignment is all right to your satisfaction (see Fig.7)

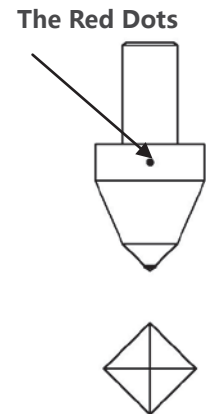

Fig 7

6.2 Light Source Adjustment (see Fig.8)

6.2.1 Turn on the power switch of the hardness tester and observe the light source of the eyepiece.

6.2.2 Fasten the Screw Two (27) in clockwise direction to make the light beam in the vision field equality. (You can loosen the Screw Three (30) and then fasten the Screw Two if it is necessary.)

6.2.3 Loosen the Screw One (26) and move it up and down.

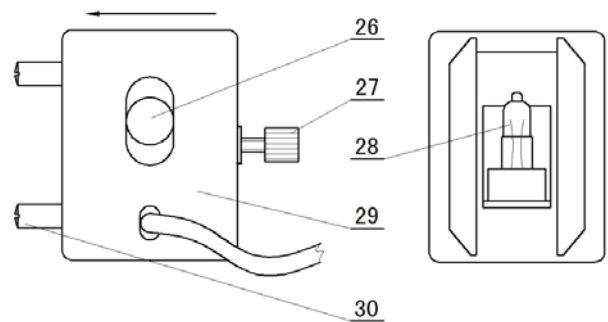

Fig 8

26.Screw One 27.Screw Two 28.Halogen Lamp 29.Back Cover 30.Screw Three

6.3 Lamp Replacement

6.3.1 Following goods is required:

- A . New lamp (a halogen lamp, 12V, 15~20W)
- B . Dry and soft cloth

6.3.2 Unscrewing the Screw two in anti-clockwise direction, push the Back Cover (29) in left direction as arrowhead marked and move the Back Cover down.

6.3.3 Take out the bad lamp (28) and replace on a new lamp and clean the lamp surface with a soft cloth.

6.3.4 Equip the Back Cover returned as above mentioned procedure.

NOTE:

1. The power switch of the hardness tester must be shut off before the lamp replacement, because there is dangerous voltage in the inside of hardness tester.
2. The replacement lamp and original lamp must be the same size and model. It will damage the circuit of hardness meter if the improper lamp is equipped.



7 Attached Lists

Table 1

Hardness Field of Hardness/Block	Repetitiveness of Value (%)		
	HV5~HV100	HV0.2~ < HV5	< HV0.2
≤225HV	≤6	≤12	≤12
> 225HV	≤4	≤8	≤10

Table 2

Hardness Symbol	Hardness tester error of the largest allowed															
	Hardness HV															
	50	100	150	200	250	300	350	400	450	500	600	700	800	900	1 000	1 500
HV 0.01																
HV 0.015	10															
HV 0.02	8															
HV 0.025	8	10														
HV 0.05	6	8	9	10												
HV 0.1	5	6	7	8	8	9	10	10	11							
HV 0.2		4		6		8		9		10	11	11	12	12		
HV 0.3		4		5		6		7		8	9	10	10	11	11	
HV 0.5		3		5		5		6		6	7	7	8	8	9	11
HV 1		3		4		4		4		5	5	5	6	6	6	8
HV 2		3		3		3		4		4	4	4	4	5	5	6
HV 3		3		3		3		3		3	4	4	4	4	4	5
HV 5		3		3		3		3		3	3	3	3	3	4	4
HV 10		3		3		3		3		3	3	3	3	3	3	3
HV 20		3		3		3		3		3	3	3	3	3	3	3
HV 30		3		3		2		2		2	2	2	2	2	2	2
HV 50		3		3		2		2		2	2	2	2	2	2	2
HV 100				3		2		2		2	2	2	2	2	2	2

- 1 When the indentation diagonal length is less than 0.020 mm, the table does not display the value.
- 2 For intermediate values, the maximum allowable error can be obtained by interpolation.
- 3 About the Micro Hardness Tester value in the table is 0.001mm or indentation diagonal length of the average of 2% of the maximum permissible error given, please select the bigger.

8 Usage Method of Knoop (HK) Hardness

8.1 Sample Introduction of Knoop Hardness

The distinguishing characteristic of Knoop test is the improvement on indenter's design. Only need to measure the long diagonal line length of indentation, therefore the relative error of measurement becomes smaller. Comparing with the micro Vickers test, when press the test force with same value, the indentation of Knoop hardness test is shallower, hence, it is suitable to test the thin sheet parts. It is used to test brittle and hard materials such as enamel, glass, agate, man-made precious stone, ceramic metals, etc.

8.2 Usage of Hardness Tester

8.2.1 When replace on the Knoop indenter, the red point on outer cylinder of indenter should face to front direction (see Fig.9).

8.2.2 Operate the key on operation board to enable the testing method change to "HK", the Knoop hardness test method.

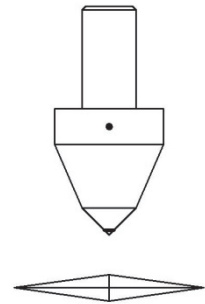

D1: 0.0	HK:	
	T:10	N:00

Fig 9

8.2.3 The operation method is just as same as that of micro Vickers hardness test, see Section 4.

8.2.4 Only require to measure the long diagonal line length of the indentation; then input the read digit. The Knoop hardness value (HK) will be displayed on the screen.

8.3 The Max. Allowed Tolerance of Displaying Value

Hardness Scale	Test Force (N)	Max Allowed Tolerance of Display Value %								
		Hardness Value (HK)								
		50	100	150	200	250	300	350	400	450
HK0.01	0.098	5	6	7	9	9	10	11	-	-
HK0.025	0.245	5	5	5	6	6	7	7	8	8
HK0.05	0.49	5	5	5	5	5	5	5	6	6
HK0.1	0.98	5	5	5	5	5	5	5	5	5
HK0.2	1.961	5	5	5	5	5	5	5	5	5
HK0.3	2.942	5	5	5	5	5	5	5	5	5
HK0.5	4.903	5	5	5	5	5	5	5	5	5
HK1	9.807	5	5	5	5	5	5	5	5	5

9 Storage/Transportation/ Attention

- Storage should be far away from the vibration, corrosion, moisture, dust, also should be stored at a normal temperature and humidity. Please put in the original packing box before transportation to avoid any damage
- Avoid rough handling in transit, so as not to cause damage to the instrument
- Transportate under the guaranteed status of the original packaging, in three levels of normal transport on the road.



ISO 9001:2015 Certified Company



Sinowon Innovation Metrology Manufacture Limited

Address:A1,KaiSong Park,2# Baima Xianfeng Road,South District,DongGuan,China (523080)

Tel:0086-769-23184144 Fax:0086-769-22854144

Web:www.sinowon.com E-mail:sinowon@188.com

Hotline:0086-137-2828-8444

Authorized Distributors: